

Time Control Technique

MINITIMER
Cyclic Timer
MK 7854N



- According to IEC/EN 61 812-1
- 8 time ranges from 0.05 s to 300 h selectable via rotational switches
- Impulse and break time separately adjustable
- Selectable start with impulse or break
- Voltage range AC/DC 12 ... 240 V
- Adjustment aid for quick setting of long time values
- Suitable for 2-wire proximity sensor control
- LED indicators for operation, contact position and time delay
- 2 changeover contacts
- Wire connection: also 2 x 1.5 mm² stranded ferruled, or 2 x 2.5 mm² solid DIN 46 228-1/-2/-3/-4
- As option 1 changeover contact instantaneously programmable
- As option connection of 2 remote potentiometers
- As option with time interruption / time adding input
- As option with pluggable terminal blocks for easy exchange of devices
 - with screw terminals
 - or with cage clamp terminals
- 22.5 mm width

Function Diagram

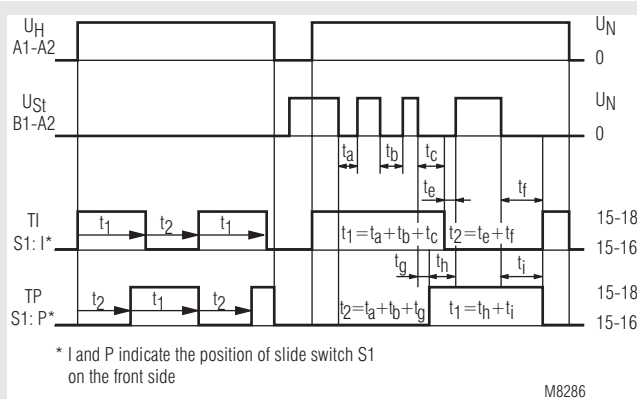

Approvals and Markings



* see variants

Application

Time-dependent controllers

Indicators

- green LED: on when voltage connected
- yellow LED "R/t": shows status of output relay and time delay:
 - Flashing (short on, long off) output relay not active; time delay t2 (break time)
 - Flashing (long on, short off) output relay active; time delay t1 (pulse time)

Circuit Diagrams

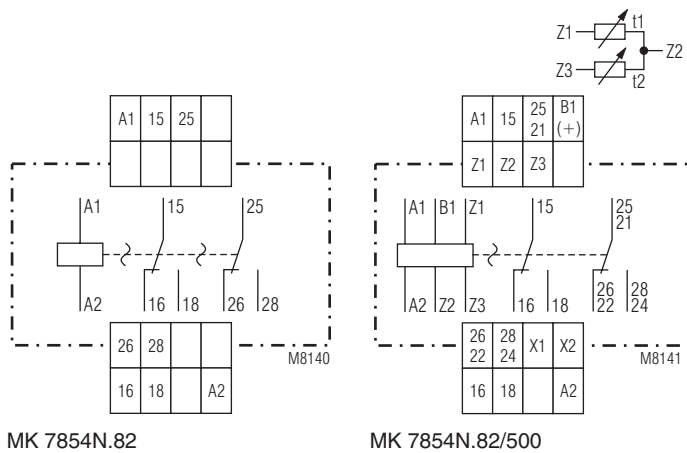

Connection Terminals

Terminal designation	Signal designation
A1	L / +
A2	N / -
15, 16, 18	Changeover contact
25, 26, 28	Changeover contact
B1(+)	Control Input (time interruption with time adding)
X1, X2	Control Input (programming 2 nd delayed C/O contact or instantaneous contact)
Z1, Z2, Z3	Input to connect two remote potentiometer for time setting t1 and t2

Notes

Control of A1-A2 with proximity sensors

The input can be controlled by DC 3 wire or AC/DC 2 wire proximity sensors. For operating voltage > 24 V and usage of sensors without built-in short circuit protection a protection resistor on A1 is recommended to reduce the inrush current. The dimension is as follows:

$R_v \approx$ operating voltage / max. switching current of sensor

The series resistor must not be selected higher than necessary.

Max. values are:

Operating voltage: 48 V 60 V 110 V 230 V
Series resistor R_v max: 270 Ω 390 Ω 680 Ω 1.8 k Ω (1 W)

Adjustment assistance

The flashing period of the yellow LED is $1 \text{ s} \pm 4\%$ and can be used to adjust the time. Especially on the lower end of scale and for long times it is suitable as the multiplication factors between the different time ranges are exact without tolerance.

Example:

The required time is 40 min. It has to be adjusted within the range 3 ... 300 min. The time check takes too long as several timing cycles would be necessary for a precise value.

For faster adjustment the setting is made to 0.03 ... 3 min. On this range the potentiometer should be set to 0.4 min. (= 24 sec). With the right potentiometer setting the LED must show 24 flashing cycles. After that the time range is switched over to 3 ... 300 min and the setting is complete.

Time interruption / Time adding

With the model MK 7854N.82/500 the timing cycle can be interrupted by controlling input B1 (+) with control voltage. Removing the control signal will continue the timing cycle (time addition). When time interrupted the yellow LED stops to flash and goes to continuous light during pulse time (output relay active), or goes off during break time (output relay inactive).

Control input B1

The control input B1 (+) has to be supplied with voltage against A2. The control signal could be the same as the auxiliary/control voltage of A1 or any other voltage between 12 and 240 V AC or DC. Operating a parallel load between B1 and A2 is possible, which allows cost saving circuits.

Instantaneous contact

By external wire lings the output function fo the variant MK 7854N.82/500 can be altered from 2 delayed contacts to 1 delayed **and** 1 instantaneous contact. The instantaneous contact switches when the operating voltage is connected.

To terminals X1 and X2 no other voltage potentials must be connected, as the unit might be damaged.

Remote potentiometers

With the variant MK 7854N.82/500 both time settings can also be made via remote potentiometers of 10 kOhms:

- Terminals Z1-Z2: potentiometer for pulse time (t_1)
- Terminals Z2-Z3: potentiometer for break time (t_2)

When connecting a remote potentiometer, the corresponding potentiometer has to be set to min. If no remote potentiometers are required the terminals Z1-Z2 resp. Z2-Z3 have to be linked.

The wires to the remote potentiometers should be installed separately from the lines with mains voltage. If this is not possible, a screened cable is recommended where the shield is connected to Z2.

To terminals Z1, Z2 and Z3 no external voltage must be connected, as the unit might be damaged.

Setting

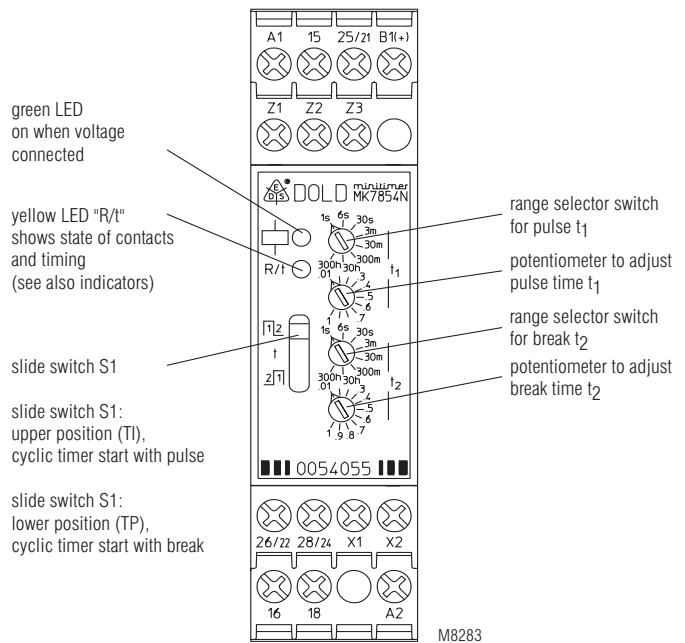

M8283

Technical Data

Time circuit

Time ranges:

8 time ranges in one unit, settable via rotational switch
0.05 ... 1 s 0.3 ... 30 min
0.06 ... 6 s 3 ... 300 min
0.3 ... 30 s 0.3 ... 30 h
0.03 ... 3 min 3 ... 300 h
continuous, 1:100 on relative scale

Time setting t_1 , t_2 :

Recovery time:

at DC 24 V: approx. 15 ms
at DC 240 V: approx. 50 ms
at AC 230 V: approx. 80 ms

Repeat accuracy:

$\pm 0.5\%$ of selected end of scale value

Voltage and

temperature influence:

< 1 % with the complete operating range

Input

Nominal voltage U_N :

AC/DC 12 ... 240 V

Voltage range:

0.8 ... 1.1 U_N

Frequency range (AC):

45 ... 400 Hz

Nominal consumption

at AC 12 V: approx. 1.5 VA
at AC 24 V: approx. 2 VA
at AC 230 V: approx. 3 VA
at DC 12 V: approx. 1 W
at DC 24 V: approx. 1 W
at DC 230 V: approx. 1 W

Release voltage (A1/A2)

Delayed contact
AC 50 Hz: approx. 7.5 V
DC: approx. 7 V
Instantaneous contact
AC 50 Hz: approx. 3 V
DC: approx. 3.3 V

Max. permitted residual current with 2-wire proximity sensor control (A1-A2)

up to AC/DC 150 V: AC resp. DC 5 mA
up to AC/DC 264 V: AC resp. DC 3 mA

Control current (B1)

MK 7854N.82/500: approx. 1 mA, over complete voltage range

Release voltage (B1/A2)

AC 50 Hz: approx. 3.5 V
DC: approx. 3 V

Technical Data

Output

Contacts:

MK 7854N.82:	2 changeover contacts
MK 7854N.82/500:	2 changeover contacts, one programmable as instantaneous contact
without bridge X1-X2:	25-26-28 delayed changeover contact
with bridge X1-X2:	21-22-24 instantaneous contact at U_N on A1-A2

Contact material:

AgNi

Measured nominal voltage: AC 250 V

Thermal current I_{th} : see quadratic total current limit curve (max. 4 A per contact)

Switching capacity

to AC 15

NO contact: 3 A / AC 230 V IEC/EN 60 947-5-1

NC contact: 1 A / AC 230 V IEC/EN 60 947-5-1

to DC 13: 1 A / DC 24 V IEC/EN 60 947-5-1

Electrical life: 1.5 x 10⁵ switching cycles

at AC 15 to 1 A, AC 230 V:

Permissible switching frequency: 36 000 switching cycles / h

Short circuit strength

max. fuse rating: 4 A gL IEC/EN 60 947-5-1

Mechanical life: 30 x 10⁶ switching cycles

General Data

Operating mode: Continuous operation

Temperature range

Operation: - 40 ... + 60 °C
(higher temperature see quadratic total current limit curve)

Storage: - 40 ... + 70 °C

Relative air humidity: 93 % at 40 °C

Altitude: < 2,000 m

Clearance and creepage distances

rated impulse voltage /

pollution degree:

Input / Output: 4 kV / 2 (basis insulation) IEC 60 664-1

Output / Output: 4 kV / 2 (basis insulation) IEC 60 664-1

Overvoltage category: III

Insulation test voltage, type test: 2.5 kV; 1 min

EMC

Electrostatic discharge: 8 kV (air) IEC/EN 61 000-4-2

HF irradiation

80 MHz ... 1 GHz: 20 V / m IEC/EN 61 000-4-3

1 GHz ... 2.7 GHz: 10 V / m IEC/EN 61 000-4-3

Fast transients: 2 kV IEC/EN 61 000-4-4

Surge voltages

between

wires for power supply: 2 kV IEC/EN 61 000-4-5

between wire and ground: 4 kV IEC/EN 61 000-4-5

HF-wire guided: 10 V IEC/EN 61 000-4-6

Interference suppression: Limit value class A*)

*) The device is designed for the usage under industrial conditions (Class A, EN 55011).

When connected to a low voltage public system (Class B, EN 55011) radio interference can be generated. To avoid this, appropriate measures have to be taken.

Degree of protection

Housing: IP 40 IEC/EN 60 529

Terminals: IP 20 IEC/EN 60 529

Housing: Thermoplastic with V0 behaviour according to UL subject 94

Vibration resistance: Amplitude 0.35 mm, frequency 10 ... 55 Hz, IEC/EN 60 068-2-6

Climate resistance: 20 / 060 / 04 IEC/EN 60 068-1

Terminal designation: EN 50 005

Technical Data

Wire connection

DIN 46 228-1/-2/-3/-4

Screw terminals

(integrated): 1 x 4 mm² solid or
1 x 2.5 mm² stranded ferruled or
2 x 1.5 mm² stranded ferruled or
2 x 2.5 mm² solid

Insulation of wires

or sleeve length: 8 mm

Plug in with screw terminals

max. cross section for connection: 1 x 2.5 mm² solid or
1 x 2.5 mm² stranded ferruled

Insulation of wires

or sleeve length: 8 mm

Plug in with cage

clamp terminals

max. cross section for connection: 1 x 4 mm² solid or
1 x 2.5 mm² stranded ferruled

min. cross section

for connection: 0.5 mm²

Insulation of wires

or sleeve length: 12 ±0.5 mm

Wire fixing: Plus-minus terminal screws M 3.5 box terminals with wire protection or cage clamp terminals

max. 0.8 Nm

DIN rail IEC/EN 60 715

Weight: 150 g

Dimensions

Width x height x depth:

MK 7854N: 22.5 x 90 x 97 mm

MK 7854N PC: 22.5 x 111 x 97 mm

MK 7854N PS: 22.5 x 104 x 97 mm

UL-Data

Switching capacity:

Ambient temperature 60°C: Pilot duty B300
5A 250Vac G.P.

Wire connection:

60°C / 75°C copper conductors only
Screw terminals fixed: AWG 20 - 12 Sol/Str Torque 0.8 Nm
Plug in screw: AWG 20 - 14 Sol Torque 0.8 Nm
AWG 20 - 16 Str Torque 0.8 Nm

Plug in cage clamp: AWG 20 - 12 Sol/Str



Technical data that is not stated in the UL-Data, can be found in the technical data section.

Standard Type

MK 7854N.82/61 AC/DC 12 ... 240 V 0.05 s ... 300 h

Article number: 0054053

- Output: 2 changeover contacts
- Nominal voltage U_N : AC/DC 12 ... 240 V
- Time ranges: 0.05 s ... 300 h
- Width: 22.5 mm

Variant

- MK 7854N.82/500/61:
- Connection facility for 2 remote potentiometers 10kOhms to adjust pulse and break time
 - 2 changeover contacts, one programmable as instantaneous contact
 - Additional control input B1 for time interruption / time addition

Ordering example for variant

MK 7854N .82 / /61 AC/DC 12 ... 240 V 0.05 s ... 300 h

Time range
Nominal voltage with UL-approval
Variant, if required
Type of terminals without indication:
terminal blocks fixed with screw terminals
PC (plug in cage clamp): pluggable terminal blocks with cage clamp terminals
PS (plug in screw): pluggable terminal blocks with screw terminals
Contacts
Type

Characteristics

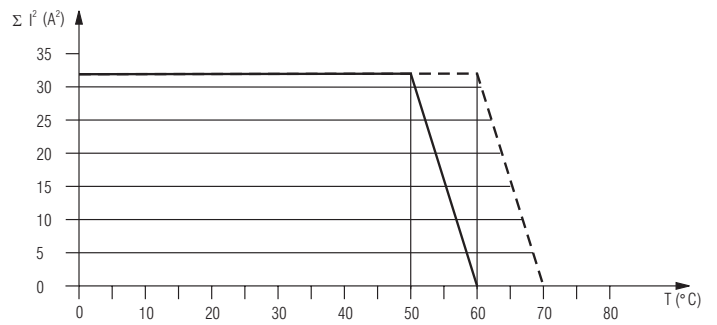

M10875

--- device mounted away from heat generation components.

— device mounted without distance heated by devices with same load.

Quadratic total current limit curve

Accessories

AD 3:

External potentiometer 10 kΩ
Article number: 0028962

The external potentiometer is used for remote setting of the time delay. The internal potentiometer of the timer must be set to min. time delay.

Degree of protection front side:

IP 60

Options with Pluggable Terminal Blocks

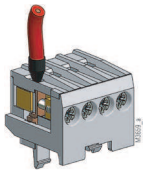

Screw terminal
(PS/plugin screw)

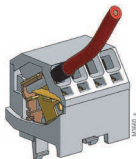

Cage clamp
(PC/plugin cage clamp)

Notes

Removing the terminal blocks with cage clamp terminals

1. The unit has to be disconnected.
2. Insert a screwdriver in the side recess of the front plate.
3. Turn the screwdriver to the right and left.
4. Please note that the terminal blocks have to be mounted on the belonging plug in terminations.

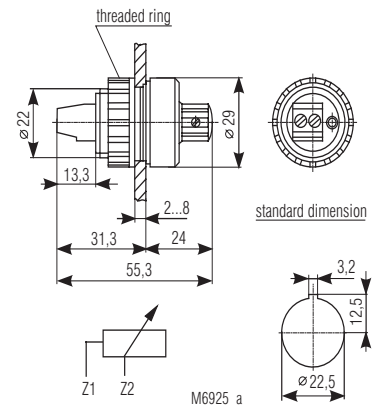
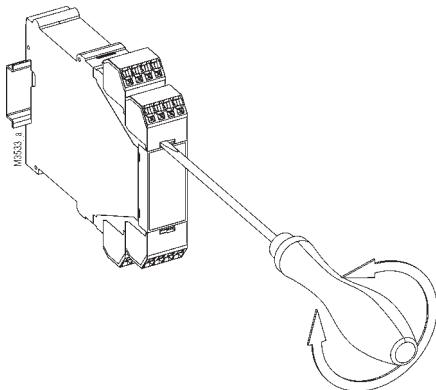

Connection Examples

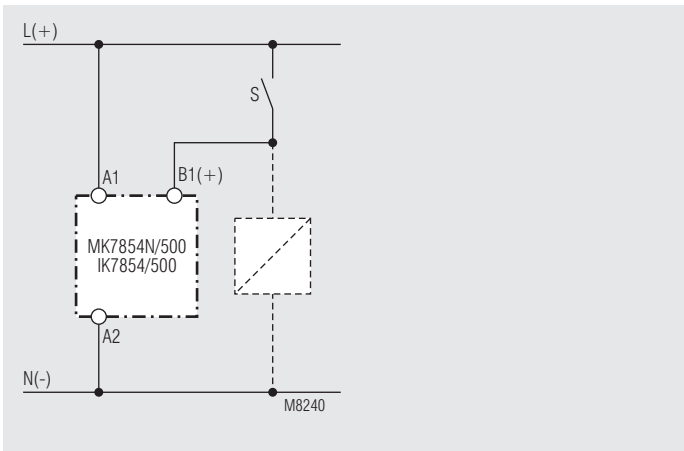
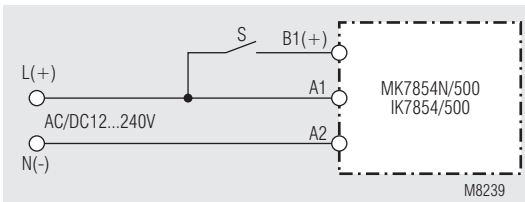

Control with parallel connected load

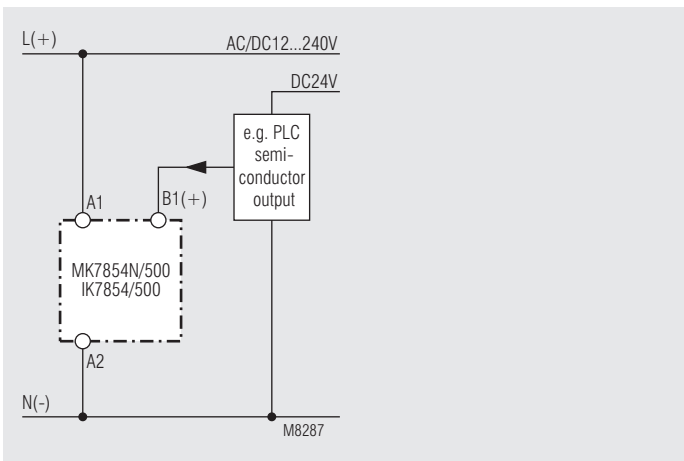

Connection with 2 different control voltages

